

DATA SHEET

TDA8809T

Radial error signal processor for
compact disc players

Product specification
File under Integrated Circuits, IC01

November 1987

Radial error signal processor for compact disc players

TDA8809T

GENERAL DESCRIPTION

The TDA8809T is a bipolar integrated circuit which provides control signals for the radial motor. These control signals are generated from radial error signals received from a photo-diode signal processor (TDA8808), and velocity control signals from the control processor.

Features

- Tracking error processor with automatic asymmetry control
- AGC circuitry with automatic start-up and wobble generator
- Tracking control for fast forward/reverse scan, search, repeat and pause functions
- Radial polarity - 4 - tracks counting
- Possibility for car, home and portable applications.

QUICK REFERENCE DATA

SYMBOL	PARAMETER	CONDITIONS	MIN.	TYP.	MAX.	UNIT
Supply						
V_P	Supply voltage range		4,5	5,0	5,5	V
	External voltage range					
$V_{ex(+)}$	pin 12		V_P	10	12	V
$V_{ext(-)}$	pin 13		-5,5	-5,0	0	V
$V_{ext(+)} - V_{ext(-)}$	pin 12 to pin 13		4,5	-	12	V
I_P	Supply current		-	5,3	-	mA
T_{amb}	Operating ambient temperature range		-30	-	+85	°C

PACKAGE OUTLINE

28-lead mini-pack; plastic (S028; SOT136A); SOT136-1; 1996 August 15.

Radial error signal processor for compact disc players

TDA8809T

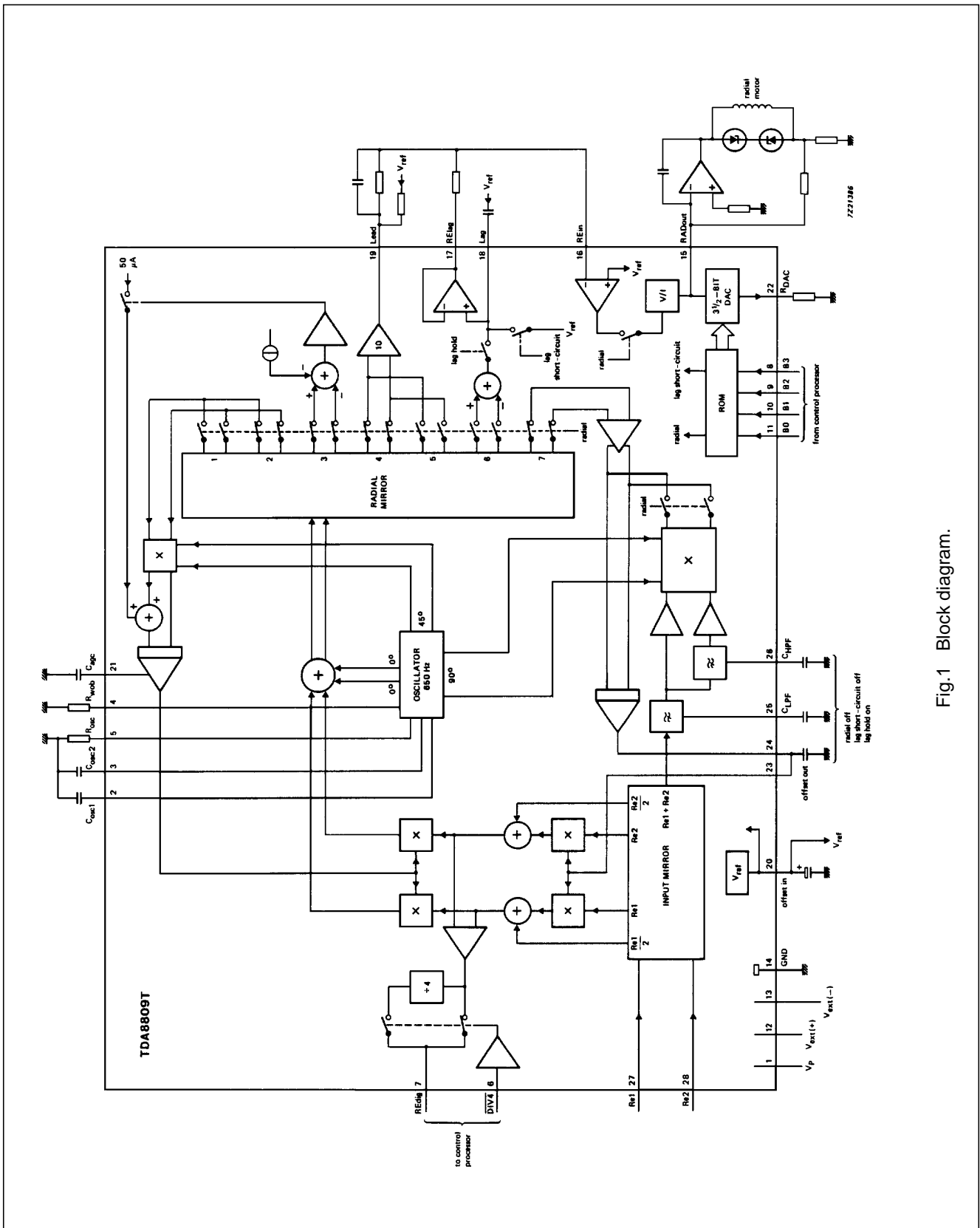

Fig.1 Block diagram.

Radial error signal processor for compact disc players

TDA8809T

PINNING

PIN	MNEMONIC	DESCRIPTION
1	V _P	Positive supply voltage
2	C _{osc1}	Frequency setting capacitors for oscillator
3	C _{osc2}	
4	R _{wob}	Wobble generator input
5	R _{osc}	Biassing resistor for oscillator frequency and internal amplitude
6	$\overline{\text{DIV4}}$	Divide-by-4 input
7	REdig	Digital output of sign (Re2 - Re1)
8	B3	Input control bits for off-, catch-, play-status and DAC output current
9	B2	
10	B1	
11	B0	
12	V _{ext(+)}	Positive external voltage input
13	V _{ext(-)}	Negative external voltage input (also substrate connection)
14	GND	Negative supply connection
15	RADout	Current output of amplified (Re2 - Re1) input currents
16	REin	Radial error input
17	RElag	Voltage output of integrated (Re2 - Re1) input currents
18	Lag	Connection of integrator capacitor for (Re1 - Re2) input currents
19	Lead	Lead output
20	V _{ref}	Internal reference voltage output
21	AGC	Gain control input for radial error signal
22	R _{DAC}	Biassing resistor for current output for track jumping (3½ bits)
23	offset in	Offset control input for radial offset
24	offset out	Offset control output for radial offset
25	C _{LPF}	Low-pass filter for Re1 and Re2, used for radial offset control
26	C _{HPF}	High-pass filter for Re1 and Re2, used for radial offset control
27	Re1	Input for amplified currents from photo-diodes D1 and D2
28	Re2	Input for amplified currents from photo diodes D3 and D4

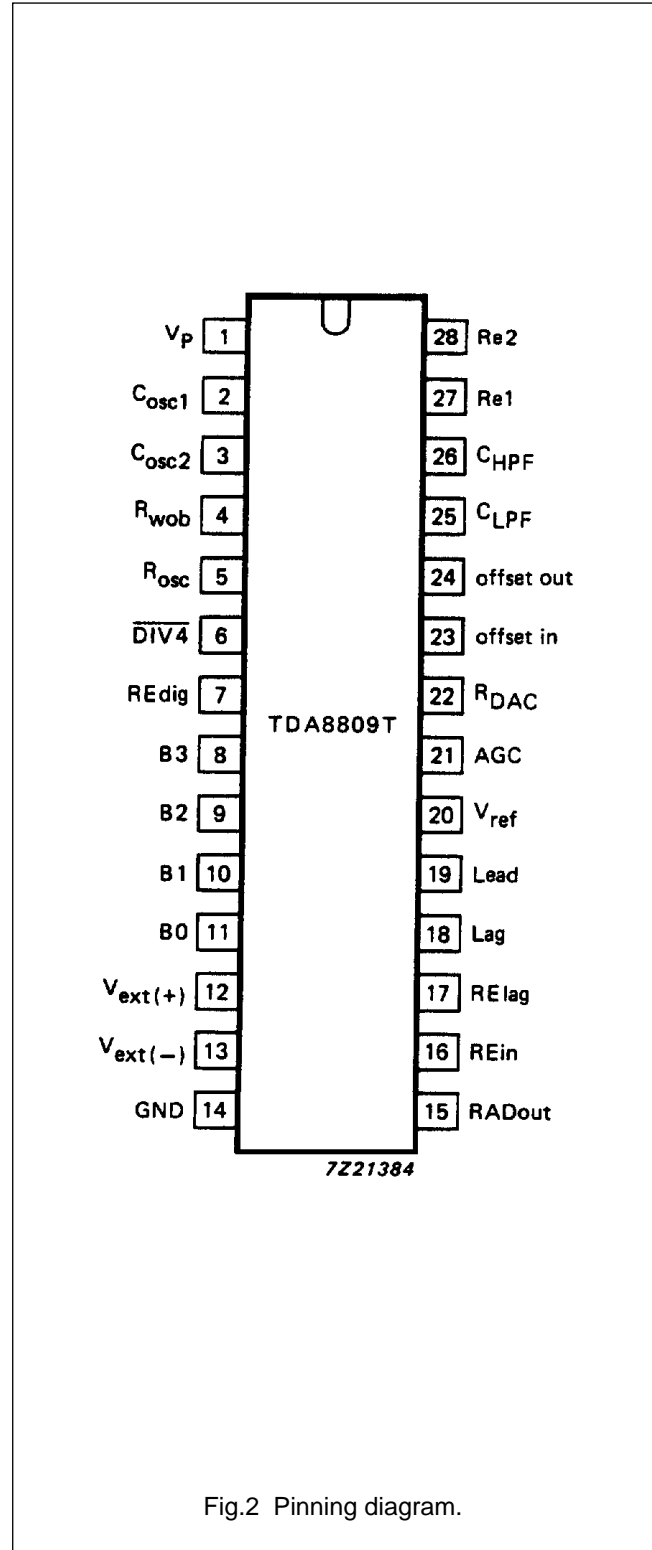

Fig.2 Pinning diagram.

Radial error signal processor for compact disc players

TDA8809T

RATINGS

Limiting values in accordance with the Absolute Maximum System (IEC 134)

SYMBOL	PARAMETER	MIN.	MAX.	UNIT
V_P	Supply voltage ranges (see Fig.3) pin 1 to pin 14	-0,3	13	V
V_{ext}	pin 12 to pin 13	-0,3	13	V
$V_{ext(-)}$	pin 14 to pin 13	-0,3	13	V
V_O	Output voltage ranges except RADout	0	V_P	V
V_O	RADout	$V_{ext(-)}$	$V_{ext(+)}$	V
I_{RDAC}	R_{DAC} current range	50	250	μA
P_{tot}	Total power dissipation	see Fig.4		
T_{stg}	Storage temperature range	-55	+150	$^{\circ}C$
T_{amb}	Operating ambient temperature range	-30	+85	$^{\circ}C$
T_j	Operating junction temperature	-	150	$^{\circ}C$

THERMAL RESISTANCE

From junction to ambient $R_{th\ j-a} = 140\ K/W$

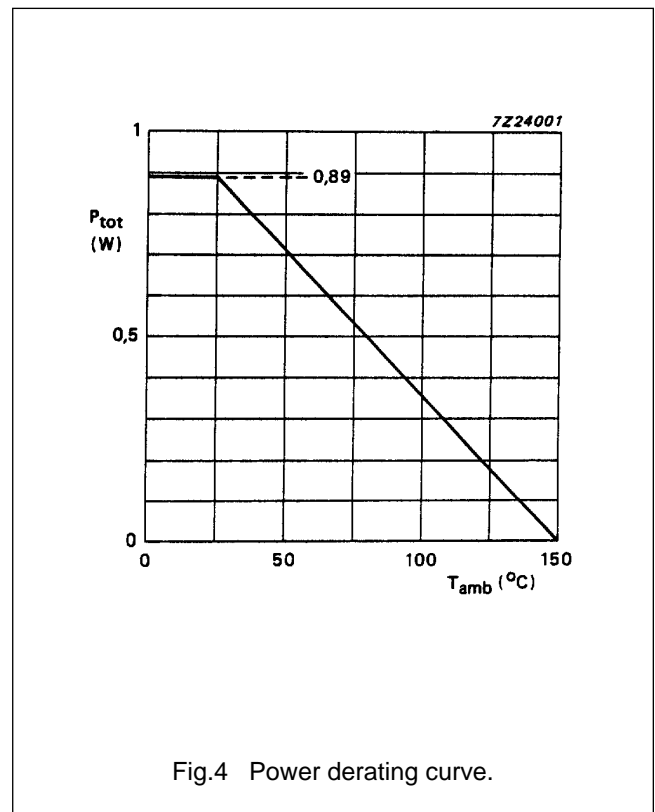
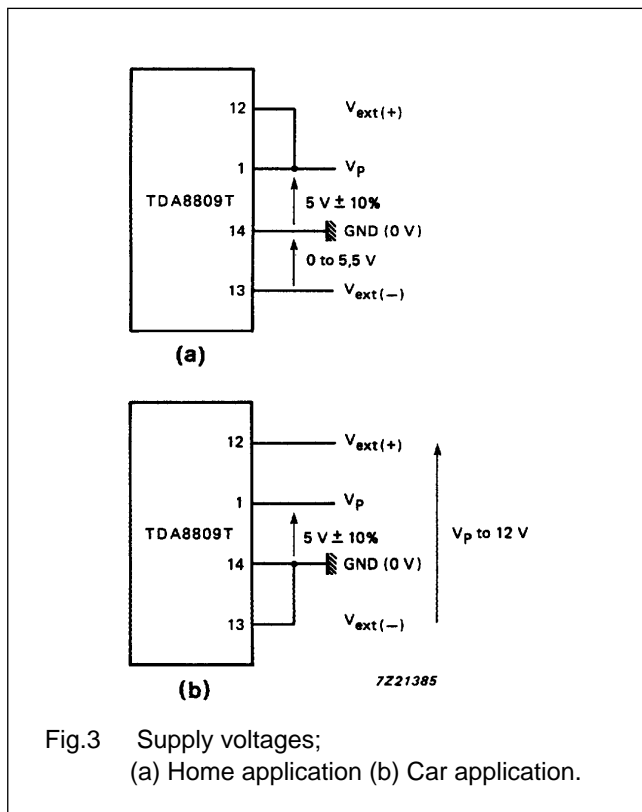

Radial error signal processor for compact disc players

TDA8809T

CHARACTERISTICS

$V_P = +5\text{ V}$; $V_{GND} = 0\text{ V}$; $V_{ext(+)} = +5\text{ V}$; $V_{ext(-)} = -5\text{ V}$; $I_{RDAC}(\text{pin } 22) = -75\text{ }\mu\text{A}$; $I_{Rwob}(\text{pin } 4) = -8\text{ }\mu\text{A}$;
 $I_{Rosc}(\text{pin } 5) = -50\text{ }\mu\text{A}$; $V_{RADout} = 0\text{ V}$; $V_{offset\ in} = V_{lead} = V_{lag} = V_{Cosc1} = V_{Cosc2} = V_{ref}$; $V_{offset\ in}$ is connected to $V_{offset\ out}$;
 $T_{amb} = 25\text{ }^\circ\text{C}$; all voltages measured with respect to V_{GND} ; unless otherwise specified.

SYMBOL	PARAMETER	CONDITIONS	MIN.	TYP.	MAX.	UNIT
Supply						
V_P	Supply voltage range		4,5	5,0	5,5	V
	External voltage range (see Fig.3)					
$V_{ext(+)}$	pin 12		V_P	10	12	V
$V_{ext(-)}$	pin 13		-5,5	-5,0	0	V
$V_{ext(+)} - V_{ext(-)}$	pin 12 to pin 13		4,5	-	12	V
I_P	Supply current		4,0	5,3	6,6	mA
Reference output (V_{ref})						
V_{ref}	Output voltage	$I_{Vref} \leq \pm 1\text{ mA}$	2,25	2,45	2,65	V
$ Z_O $	Output impedance		-	25	-	Ω
Reference input (R_{osc})						
V_{Rosc}	Input voltage level	$I_{Rosc} = -50\text{ }\mu\text{A}$	1,1	1,24	1,3	V
I_{Rosc}	Input current		-	-50	-	μA
Reference input (R_{DAC})						
V_{RDAC}	Input voltage level	$I_{RDAC} = -75\text{ }\mu\text{A}$	1,1	1,23	1,3	V
I_{RDAC}	Input current		-	-75	-	μA
Reference input (R_{wob})						
V_{Rwob}	Input voltage level	$I_{Rwob} = -8\text{ }\mu\text{A}$	150	165	180	mV
I_{Rwob}	Input current		-	-8	-	μA
REdig output (REdig)						
I_{REdig}	Output source current	note 1 (A)	-	-160	-50	μA
I_{REdig}	Output sink current	note 1 (B)	0,4	3,5	-	mA
V_{REdig}	Output voltage HIGH	$I_{REdig} = -50\text{ }\mu\text{A}$; note 1 (A)	2,4	-	-	V
V_{REdig}	Output voltage LOW	$I_{REdig} = 400\text{ }\mu\text{A}$; note 1 (B)	0	0,13	0,4	V

Radial error signal processor for compact disc players

TDA8809T

SYMBOL	PARAMETER	CONDITIONS	MIN.	TYP.	MAX.	UNIT
Digital inputs						
V_{IH}	B0, B1, B2 and B3 Input voltage HIGH	note 2	2,0	–	V_P	V
V_{IL}	Input voltage LOW	note 2	0	–	0,8	V
I_{IH}	Input sink current HIGH		0	0,03	1,0	μA
I_{IL}	Input source current LOW		–3,0	–0,1	0	μA
Divide-by-4 input (DIV4)						
V_{IH}	Input voltage HIGH	divide-by-1	2,0	–	V_P	V
V_{IL}	Input voltage LOW	divide-by-4	0	–	0,8	V
I_{IH}	Input sink current HIGH		0	5,0	(5)	μA
I_{IL}	Input source current LOW		–10	–3	0	μA
f_i	Input frequency at Re1 and Re2		–	10	50	kHz
Radial error inputs (Re1; Re2)						
V_{Re1}, V_{Re2}	Input voltage level	$I_{Re1} = I_{Re2} = -110 \mu\text{A}$	$V_P - 1,81$	$V_P - 1,71$	$V_P - 1,61$	V
I_{Re1}, I_{Re2}	Input current		–	–110	–	μA
$ Z_{Re1} , Z_{Re2} $	Input impedance		–	2,5	–	k Ω
Gain control input (AGC)		rad on; lag hold off				
I_{AGC}	Offset current	$V_{AGC} = 3,8 \text{ V};$ $I_{Re1} = I_{Re2} = 0$	–0,2	0	0,2	μA
I_{lag}	Lag current for minimum radial gain	$I_{Re1} = -85 \mu\text{A};$ $I_{Re2} = -115 \mu\text{A}$ $V_{AGC} = 0,6 \text{ V}$	–2,5	–0,45	+1,5	μA
I_{lag}	maximum radial gain	$V_{AGC} = 3,8 \text{ V}$	–42	–30	–18	μA
$ Z_{AGC} $	Input impedance		–	(5)	–	M Ω
I_{AGC0}	Gain	$V_{AGC} = 3,8 \text{ V};$ $V_{Cosc2} = V_{ref} + 1,4 \text{ V};$ $V_{Cosc1} = V_{ref};$ $I_{Re1} = -100 \mu\text{A};$ $I_{Re2} = -100 \mu\text{A}$ $I_{Re1} - I_{Re2} = 4 \mu\text{A}$ – I_{AGC0} then $I_{Re1} - I_{Re2} = -4 \mu\text{A}$ – I_{AGC0}	–	–2	–	μA
$\frac{\Delta I_{AGC}}{\Delta(I_{Re1} - I_{Re2})}$			0,7	0,9	1,1	

Radial error signal processor for compact disc players

TDA8809T

SYMBOL	PARAMETER	CONDITIONS	MIN.	TYP.	MAX.	UNIT
Gain control (continued)						
I_{AGC}	Radial error trackcrossing	rad off; $V_{AGC} = 3,8 \text{ V}$ $I_{Re2} - I_{Re1} = -12 \mu\text{A}$; $I_{Re2} + I_{Re1} = -200 \mu\text{A}$	-3	0	3	μA
I_{AGC}		$I_{Re2} - I_{Re1} = -48 \mu\text{A}$; $I_{Re2} + I_{Re1} = -200 \mu\text{A}$	39	49	59	μA
Offset control (offset out)						
$I_{\text{offset out}}$	Offset current	rad on; $I_{CHPF} = 0$; $I_{Re1} = I_{Re2} = -110 \mu\text{A}$	-0,1	0	0,1	μA
I_{lag}	Offset lag current for minimum amplification Re1	rad on; lag hold off; $V_{AGC} = 3,8 \text{ V}$; $I_{Re1} = I_{Re2} = -110 \mu\text{A}$ $V_{\text{offset in}} =$ $V_{\text{ref}} - 1,2 \text{ V}$	-115	-100	-85	μA
I_{lag}	maximum amplification Re2	$V_{\text{offset in}} =$ $V_{\text{ref}} + 1,2 \text{ V}$	+85	+100	+115	μA
I_{lag}	minimum amplification Re2	$V_{\text{offset in}} =$ note 3	-7	0	+7	μA
I_{lag}	maximum amplification Re1					
I_{lag}	Offset lag current					
Transconductance factor						
$\frac{\Delta I_{\text{offset out}}}{\Delta V_{\text{offset in}} \cdot I_{\text{tot}}}$		rad off; $V_{AGC} = 3,8 \text{ V}$; $I_{Re1} = I_{Re2} = -100 \mu\text{A}$; $V_{\text{range offset in}} =$ 0,6 V (int.); $I_{\text{tot}} = I_{Re1} + I_{Re2}$	0,17	0,21	0,25	
$\frac{\Delta I_{\text{offset out}}}{\Delta V_{\text{offset in}} \cdot I_{\text{tot}}}$		rad off; $V_{AGC} = V_{\text{GND}}$ $I_{Re1} = I_{Re2} = -100 \mu\text{A}$; $V_{\text{range offset in}} =$ 0,6 V (int.); $I_{\text{tot}} = I_{Re1} + I_{Re2}$	-0,1	0	0,1	
$ Z_{\text{offset in}} $	Input impedance		-	(5)	-	$\text{M}\Omega$

Radial error signal processor for compact disc players

TDA8809T

SYMBOL	PARAMETER	CONDITIONS	MIN.	TYP.	MAX.	UNIT
High-pass filter (C_{HPF})						
V_{CHPF}	Voltage level at $I_{CHPF} = 0$	$I_{Re1} = I_{Re2} = 0$; $I_{CLPF} = 0$	$V_P - 0,82$	$V_P - 0,72$	$V_P - 0,62$	V
$\frac{\Delta V_{CHPF}}{\Delta(I_{Re1} - I_{Re2})}$	Transresistance from Re1, Re2 to C_{HPF}	$I_{Re1} + I_{Re2} = -200 \mu A$	-200	(5)	200	Ω
$\frac{\Delta V_{CHPF}}{\Delta(I_{Re1} + I_{Re2})}$			6,2	8,8	11,5	$k\Omega$
$ Z_{CHPF} $	Input impedance		-	8	-	$k\Omega$
Low-pass filter (C_{LPF})						
V_{CLPF}	Voltage level at $I_{CLPF} = 0$	$I_{Re1} = I_{Re2} = 0$	4,7	-	V_P	V
$ Z_{CLPF} $	Input impedance		-	8	-	$k\Omega$
RElag output						
V_{RElag}	Output voltage range	$I_{RElag} = -200 \mu A$; $V_{lag} = 4,25 V$	$V_P - 1,1$	-	-	V
V_{RElag}		$I_{RElag} = 200 \mu A$; $V_{lag} = 0,9 V$	-	-	1,1	V
I_{RElag}	Maximum source current output	$V_{lag} = 4,1 V$	-6,0	-3,5	-1,0	mA
I_{RElag}	Maximum sink current output	$V_{lag} = 0,9 V$	2,5	4,1	5,5	mA
$ Z_{RElag} $	Output impedance	$f = < 10 kHz$	-	-	50	Ω
$V_{RElag \text{ offset}}$	Offset ($V_{RElag} - V_{ref}$)	lag short-circuit on; lag hold on	-10	-	10	mV
$\frac{V_{RElag}}{V_{lag}}$	Transfer lag \rightarrow RElag	$f = < 10 kHz$; lag short-circuit off; lag hold on	-5%	1	5%	
SR	Slew rate RElag output amplifier	lag short-circuit off; lag hold on	-	0,4	-	V/ μs

Radial error signal processor for compact disc players

TDA8809T

SYMBOL	PARAMETER	CONDITIONS	MIN.	TYP.	MAX.	UNIT
Lag push-pull current output, voltage input (pin 18)						
V_{lag}	Output voltage	note 4 $I_{lag} = -20 \mu A;$ $V_{offset in} = V_{ref} - 1,2 V$	$V_P - 1,5$	–	–	V
V_{lag}		$I_{lag} = 20 \mu A;$ $V_{offset} = V_{ref} + 1,2 V$	–	–	1,5	V
$ Z_{lag} $	Output impedance		–	(5)	–	M Ω
Switch lag short-circuit						
$ Z_{lag sc} $	Impedance $\frac{\Delta V_{lag}}{\Delta V_{lag}}$	lag short-circuit on; lag hold on; $I_{lag} = \pm 100 \mu A$	–	0,4	1	k Ω
Radial error input (REin)						
$ Z_{REin} $	Input impedance	rad on	–	0	–	k Ω

Radial error signal processor for compact disc players

TDA8809T

SYMBOL	PARAMETER	CONDITIONS	MIN.	TYP.	MAX.	UNIT
RADout push-pull current output						
V_{RADout}	Output voltage	rad on $I_{REin} = 180 \mu A$; $I_{RADout} = -50 \mu A$	$V_{ext(+)} - 1,5$	–	–	V
V_{RADout}		$I_{REin} = -180 \mu A$; $I_{RADout} = 50 \mu A$	–	–	$V_{ext(-)} + 1,5$	V
$\frac{I_{RADout}}{I_{REin}}$	Current gain	rad on; $I_{REin} = \pm 100 \mu A$	-10%	1	10%	
SR	Slew rate		–	0,4	–	V/ μs
$ Z_{RADout} $	Output impedance		–	(5)	–	M Ω
$\frac{I_{RADout}}{I_{RDAC}}$	Ratio of output current to reference current	$I_{REin} = 0$; $I_{RDAC} = -75 \mu A$; see also Table 1				
			-5%	-0,5	+15%	
			-8%	-2	+12%	
			-0,02	0	0,02	
			-0,02	0	0,02	
			-14%	0,5	+6%	
			-12%	2	+8%	
			-0,1	0	0,1	
			-0,1	0	0,1	
			-5%	-0,5	+15%	
			-5%	-0,375	+15%	
			-5%	-0,25	+15%	
			-4%	-0,125	+16%	
			-14%	+0,5	+6%	
			-13%	+0,375	+7%	
			-13%	+0,25	+7%	
			-13%	+0,125	+7%	

Radial error signal processor for compact disc players

TDA8809T

SYMBOL	PARAMETER	CONDITIONS	MIN.	TYP.	MAX.	UNIT
Lead output		$V_{AGC} = 3,8 \text{ V}$				
V_{lead}	Output voltage	$I_{\text{Re1}} = -90 \mu\text{A};$ $I_{\text{Re2}} = -100 \mu\text{A};$ $I_{\text{lead}} = -20 \mu\text{A}$	$V_P - 1,5$	–	–	V
V_{lead}	Offset current	$I_{\text{lead}} = 20 \mu\text{A}$	–	–	1,5	V
$I_{\text{lead offset}}$		$I_{\text{Re1}} = I_{\text{Re2}} = -100 \mu\text{A}$	–100	0	100	μA
$\frac{\Delta I_{\text{lead}}}{\Delta (I_{\text{Re1}} - I_{\text{Re2}})}$	Current gain	$I_{\text{Re1}} = -120 \mu\text{A};$ $I_{\text{Re2}} = -100 \mu\text{A}$	–11,2	–9,9	–8,8	
$ Z_{\text{lead}} $	Output impedance		–	(5)	–	$\text{M}\Omega$
Oscillator						
	(C_{osc1} and C_{osc2} connected to 12 nF capacitors)					
$V_{\text{osc1(p-p)}}$	Amplitude oscillation (peak-to-peak value) C_{osc1}		1,05	1,25	1,45	V
$V_{\text{osc2(p-p)}}$	C_{osc2}		1,05	1,25	1,45	V
f_{osc}	Operating frequency	$I_{\text{Re1}} = I_{\text{Re2}} = -110 \mu\text{A}$	690	740	790	Hz
	Output voltages (peak-to-peak value)					
<i>0° injection</i>						
$V_{\text{lead(p-p)}}$	lead (pin19)	$R_{\text{lead}} = 10 \text{ k}\Omega$	0,85	1,05	1,25	V
$V_{\text{lag(p-p)}}$	C_{lag} (pin 18)	$R_{\text{lag}} = 10 \text{ k}\Omega$; rad on;	85	105	125	mV
$V_{\text{lag(p-p)}}$		lag hold off	–	0	20	mV
		rad on; lag hold on				
<i>90° injection</i>						
$V_{\text{offset out(p-p)}}$	offset out	$I_{\text{CHPF}} = -100 \mu\text{A};$ $R_{\text{offset out}} = 10 \text{ k}\Omega;$ rad on	90	110	130	mV
<i>45° injection</i>						
$V_{\text{AGC(p-p)}}$	AGC	$R_{\text{agc}} = 10 \text{ k}\Omega$ $V_{\text{offset in}} = V_{\text{ref}} + 1\text{V};$ rad on	200	250	300	mV

Radial error signal processor for compact disc players

TDA8809T

Notes to the characteristics

- REdig output conditions:
(A) $I_{Re1} > I_{Re2} + 5 \mu A$; (B) $I_{Re2} > I_{Re1} + 5 \mu A$.
- Input voltage HIGH indicates logic 1; Input voltage LOW indicates logic 0; see also Table 1.
- $\overline{DIV4} = \text{HIGH}$; $V_{\text{offset in}}$ adjusted for $V_{\text{REdig}} = 1,4 \text{ V}$; rad on; lag hold off; $V_{\text{AGC}} = 3,8 \text{ V}$;
 $I_{Re1} = I_{Re2} = -100 \mu A$.
- Output voltage conditions are:
rad on; lag short-circuit off; lag hold off; $V_{\text{AGC}} = 3,8 \text{ V}$; $I_{Re1} = I_{Re2} = -100 \mu A$;
 $V_{\text{offset}} = V_{\text{ref}} - 1,2 \text{ V}$.
- Value to be fixed.

Table 1 Truth table for DAC output current

FUNCTIONS	DAC OUTPUT $I_{\text{REout}}/I_{\text{DAC}}$	LOGICAL INPUTS				INTERNAL SWITCHES		
		B3	B2	B1	B0	lag s/c	rad	lag hold
PUSH	-1/2	0	0	0	0	off	off	on
(kick)	-2	0	0	0	1	off	off	off
OFF	0	0	0	1	0	off	off	on
OFF	0	0	0	1	1	on	off	off
PULL	1/2	0	1	0	0	off	off	on
(kick)	2	0	1	0	1	off	off	off
CATCH	0	0	1	1	0	off	on	on
PLAY	0	0	1	1	1	off	on	off
PUSH	-1/2	1	0	0	0	on	off	on
PUSH	-3/8	1	0	0	1	on	off	off
PUSH	-1/4	1	0	1	0	on	off	on
PUSH	-1/8	1	0	1	1	on	off	off
PULL	1/2	1	1	0	0	on	off	on
PULL	3/8	1	1	0	1	on	off	off
PULL	1/4	1	1	1	0	on	off	on
PULL	1/8	1	1	1	1	on	off	off

Where:

0 = input voltage LOW; 1 = input voltage HIGH.

Radial error signal processor for compact disc players

TDA8809T

PACKAGE OUTLINE

SO28: plastic small outline package; 28 leads; body width 7.5 mm

SOT136-1

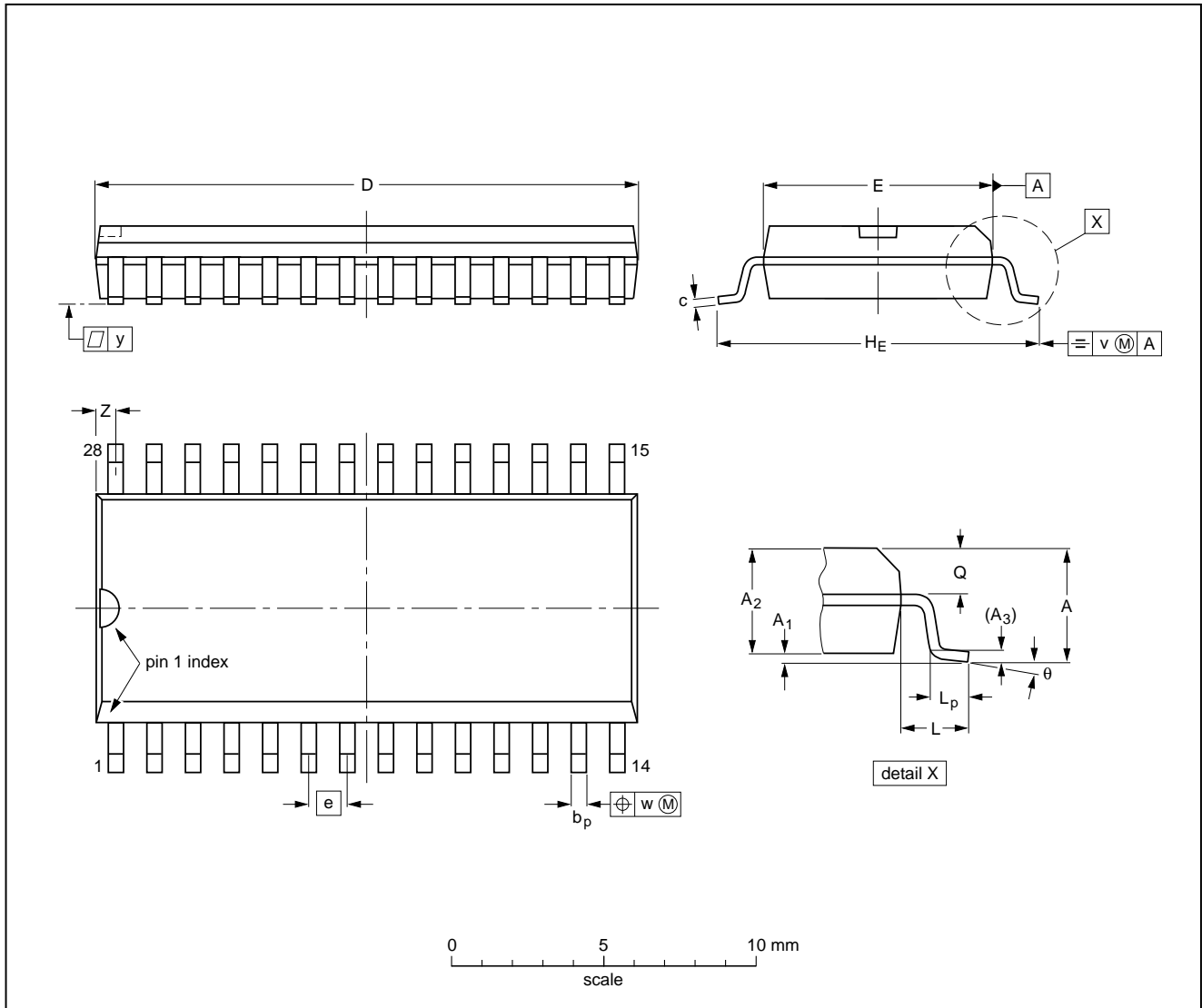

DIMENSIONS (inch dimensions are derived from the original mm dimensions)

UNIT	A max.	A ₁	A ₂	A ₃	b _p	c	D ⁽¹⁾	E ⁽¹⁾	e	H _E	L	L _p	Q	v	w	y	Z ⁽¹⁾	θ
mm	2.65	0.30 0.10	2.45 2.25	0.25	0.49 0.36	0.32 0.23	18.1 17.7	7.6 7.4	1.27	10.65 10.00	1.4	1.1 0.4	1.1 1.0	0.25	0.25	0.1	0.9 0.4	8° 0°
inches	0.10	0.012 0.004	0.096 0.089	0.01	0.019 0.014	0.013 0.009	0.71 0.69	0.30 0.29	0.050	0.42 0.39	0.055	0.043 0.016	0.043 0.039	0.01	0.01	0.004	0.035 0.016	

Note

1. Plastic or metal protrusions of 0.15 mm maximum per side are not included.

OUTLINE VERSION	REFERENCES				EUROPEAN PROJECTION	ISSUE DATE
	IEC	JEDEC	EIAJ			
SOT136-1	075E06	MS-013AE				91-08-13 95-01-24

Radial error signal processor for compact disc players

TDA8809T

SOLDERING

Introduction

There is no soldering method that is ideal for all IC packages. Wave soldering is often preferred when through-hole and surface mounted components are mixed on one printed-circuit board. However, wave soldering is not always suitable for surface mounted ICs, or for printed-circuits with high population densities. In these situations reflow soldering is often used.

This text gives a very brief insight to a complex technology. A more in-depth account of soldering ICs can be found in our "*IC Package Databook*" (order code 9398 652 90011).

Reflow soldering

Reflow soldering techniques are suitable for all SO packages.

Reflow soldering requires solder paste (a suspension of fine solder particles, flux and binding agent) to be applied to the printed-circuit board by screen printing, stencilling or pressure-syringe dispensing before package placement.

Several techniques exist for reflowing; for example, thermal conduction by heated belt. Dwell times vary between 50 and 300 seconds depending on heating method. Typical reflow temperatures range from 215 to 250 °C.

Preheating is necessary to dry the paste and evaporate the binding agent. Preheating duration: 45 minutes at 45 °C.

Wave soldering

Wave soldering techniques can be used for all SO packages if the following conditions are observed:

- A double-wave (a turbulent wave with high upward pressure followed by a smooth laminar wave) soldering technique should be used.
- The longitudinal axis of the package footprint must be parallel to the solder flow.
- The package footprint must incorporate solder thieves at the downstream end.

During placement and before soldering, the package must be fixed with a droplet of adhesive. The adhesive can be applied by screen printing, pin transfer or syringe dispensing. The package can be soldered after the adhesive is cured.

Maximum permissible solder temperature is 260 °C, and maximum duration of package immersion in solder is 10 seconds, if cooled to less than 150 °C within 6 seconds. Typical dwell time is 4 seconds at 250 °C.

A mildly-activated flux will eliminate the need for removal of corrosive residues in most applications.

Repairing soldered joints

Fix the component by first soldering two diagonally-opposite end leads. Use only a low voltage soldering iron (less than 24 V) applied to the flat part of the lead. Contact time must be limited to 10 seconds at up to 300 °C. When using a dedicated tool, all other leads can be soldered in one operation within 2 to 5 seconds between 270 and 320 °C.

Radial error signal processor for compact disc players

TDA8809T

DEFINITIONS

Data sheet status	
Objective specification	This data sheet contains target or goal specifications for product development.
Preliminary specification	This data sheet contains preliminary data; supplementary data may be published later.
Product specification	This data sheet contains final product specifications.
Limiting values	
Limiting values given are in accordance with the Absolute Maximum Rating System (IEC 134). Stress above one or more of the limiting values may cause permanent damage to the device. These are stress ratings only and operation of the device at these or at any other conditions above those given in the Characteristics sections of the specification is not implied. Exposure to limiting values for extended periods may affect device reliability.	
Application information	
Where application information is given, it is advisory and does not form part of the specification.	

LIFE SUPPORT APPLICATIONS

These products are not designed for use in life support appliances, devices, or systems where malfunction of these products can reasonably be expected to result in personal injury. Philips customers using or selling these products for use in such applications do so at their own risk and agree to fully indemnify Philips for any damages resulting from such improper use or sale.